

HC/RD-36/42

Appliance Specifications

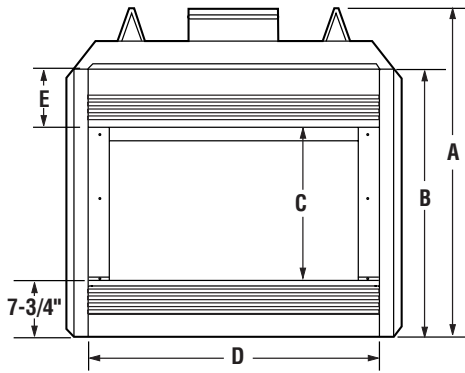

Front View

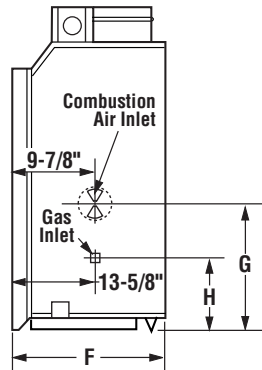

Right Side View

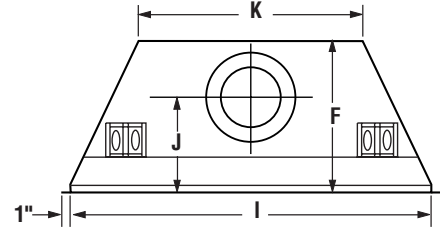

Top View

	A	B	C	D	E	F	G	H	I	J	K
HC/RD-36	41-1/4"	36-5/16"	20-3/16"	36"	9"	21-5/16"	17-7/16"	10-1/8"	41-3/4"	13-1/4"	28-1/8"
HC/RD-42	46-3/8"	38-7/16"	22-5/16"	41"	8-3/8"	23-1/2"	17-5/16"	10"	46-3/4"	15"	31-9/16"

Fireplace Finishes

Mantels and Trim

These fireplaces may sit directly on a combustible surface. A 2" air space is required between combustible framing and the chimney. Combustible mantels and trim may be installed 12" above the fireplace opening as per NFPA 211, Section 7-2.3.3, and Figure below. If a mantel is of a noncombustible material, it is exempt from these requirements as long as it does not interfere with the installation or operation of glass doors.

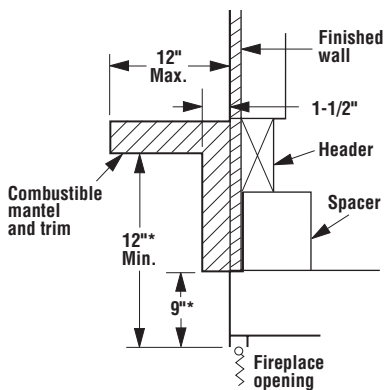

Mantel Limitation

*Both of these dimensions must add up to at least 18" when an unvented gas log set rated at (26,000 Btu/hr for 36" unit and 32,000 Btu/hr for 42" unit) or higher is used. (maximum 40,000 Btu/hr)

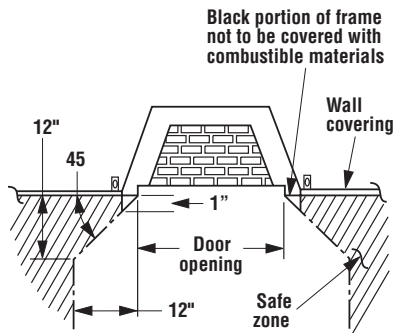

Vertical Surround Limitations

Hearth Extensions Dimensions

	36	42
A	16"	16"
B	32"	38"
C	8"	8"
D	48"	54"

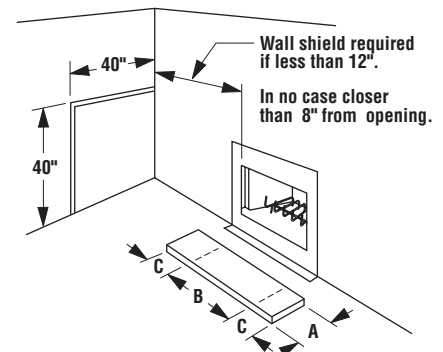

Hearth Extensions & Wall Shields

HC/RD-36/42

Framing Specifications

Note: Framing dimensions are calculated for a nailing flange depth of 1/2"

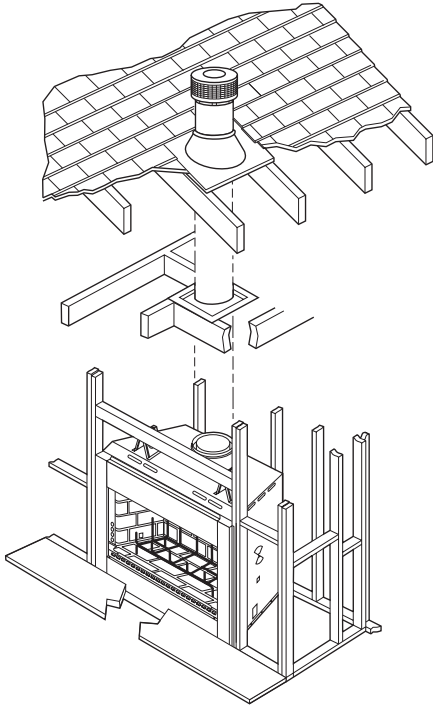

Typical Installation

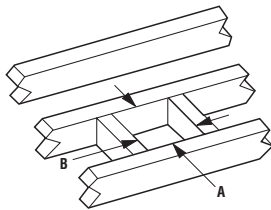

Ceiling Framing

Framing Dimensions For Ceiling

Flue Type	A	B
TF8 Vertical	16-1/2"	16-1/2"
TF8 Offset 30°	16-1/2"	27"

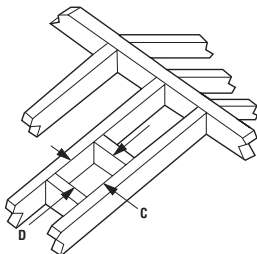

Roof Framing

Roof Framing Dimensions

Pitch	C	D
0/12	16-1/2"	16-1/2"
6/12	16-1/2"	19"
12/12	16-1/2"	23-1/2"

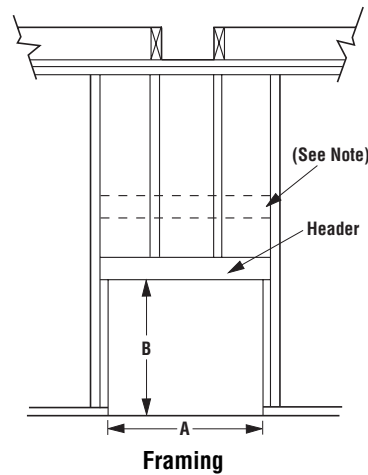
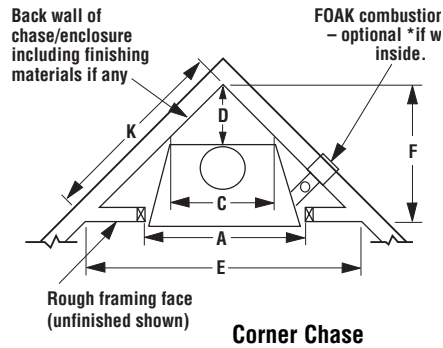
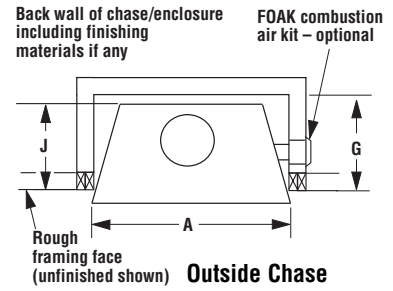
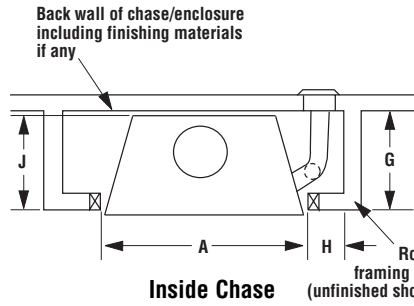

Note: When framing with 6" studs header must be 17" higher. Use FCT OR15 offset/return elbow to recess the chimney back 2-1/2". Flat frame down to a false header at (B). Maintain required clearance to chimney at all times.

Framing Dimensions

	A	B	C	D	E	F	G	H*	J	K
HC/RD-36	43"	44-1/2"	29-1/2"	15-3/4"	73"	36-1/2"	21-3/4"	51-5/8"	20-3/4"	51-5/8"
HC/RD-42	48"	46-1/2"	33"	17-1/2"	80-3/4"	40-3/8"	23-7/8"	57-1/8"	22-7/8"	57"

* when FATO is used.

Note: All dimensions calculated for 1/2" dry wall at the appliance face. If sheathing the chase or finishing with other thickness materials, calculations will need to be made.

